

**CS-01
CT-01 Series**

Draw Latch (Spring Loaded Type)

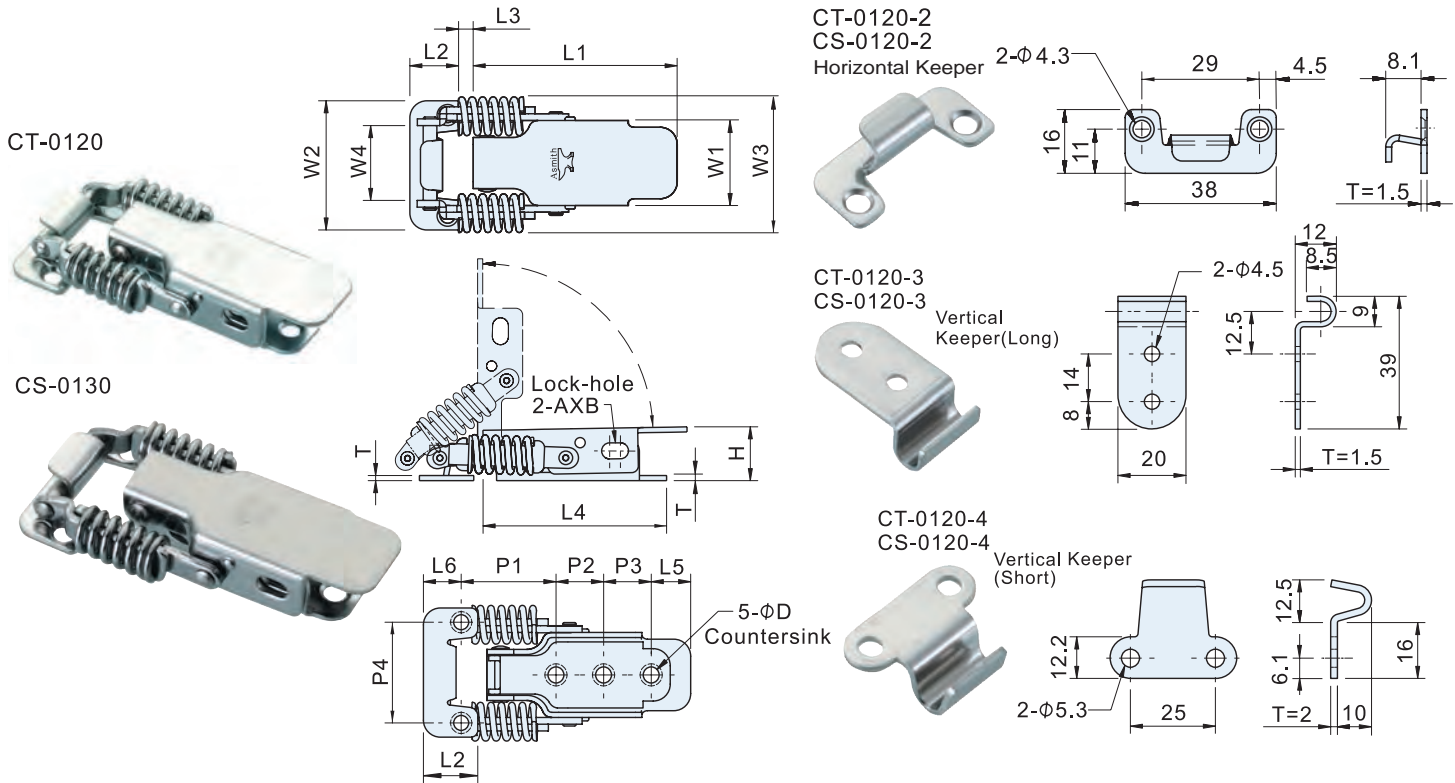

MATERIAL AND FINISH

- Cold-rolled Steel (SPCC), Zinc Plated.
- Stainless steel (SUS304), Vibration ground and Satin polishing.

FEATURES

- 2 springs provide strong and average compression force.
- Standard Lock-hole.
- 3 types of keepers, suitable for various applications.

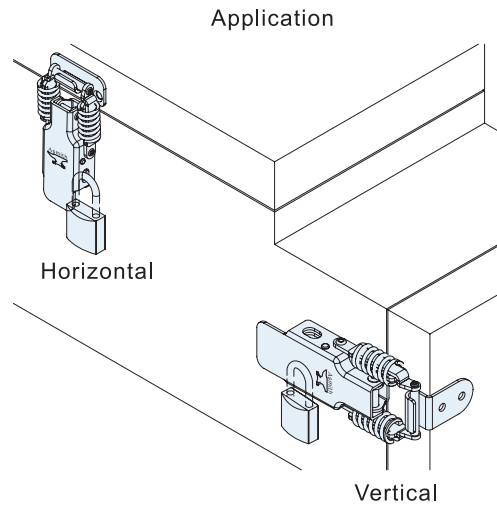

SPECIFICATIONS:(Use Horizontal Keeper)

Unit:mm

Item No.	Material	Dimensions																		
		L1	L2	L3	L4	L5	L6	W1	W2	W3	W4	H	T	P1	P2	P3	P4	D	AXB	
CT-0120	SPCC	60	16	5.5~8.5	54	11.8	11	24	38	40	22	15	1.5	31~34	14	14	29	4.3	7.5X4.7	71
CS-0120	SUS304	60	16	5.5~8.5	54	11.8	11	24	38	40	22	15	1.5	31~34	14	14	29	4.3	7.5X4.7	69
CT-0130	SPCC	80	19	6~9	68.5	18.5	13	32	50	50	28	18	2.0	38~41	18	18	38	5.3	10X6.5	140
CS-0130	SUS304	80	19	6~9	68.5	18.5	13	32	50	50	28	18	2.0	38~41	18	18	38	5.3	10X6.5	136

Vertical Keeper:

Item No.	Type	Material	Apply to	Weight(g)
CT-0120-3	Long 3	SPCC	CT-0120-1 · CT-0130-1	11.2
CS-0120-3		SUS304	CS-0120-1 · CS-0130-1	11.0
CT-0120-4	Short 4	SPCC	CT-0120-1 · CT-0130-1	14.8
CS-0120-4		SUS304	CS-0120-1 · CS-0130-1	14.4

Compression Force:

Item No.	Extension length				mm
	1	2	3	4	
CT-0120	28	36	41	47	kg
CS-0120	22	27	33	38	
CT-0130	29	36	40	50	
CS-0130	28	34	41	44	