

CS-22
CT-22 Series

Draw Latch
(Spring Loaded Type)

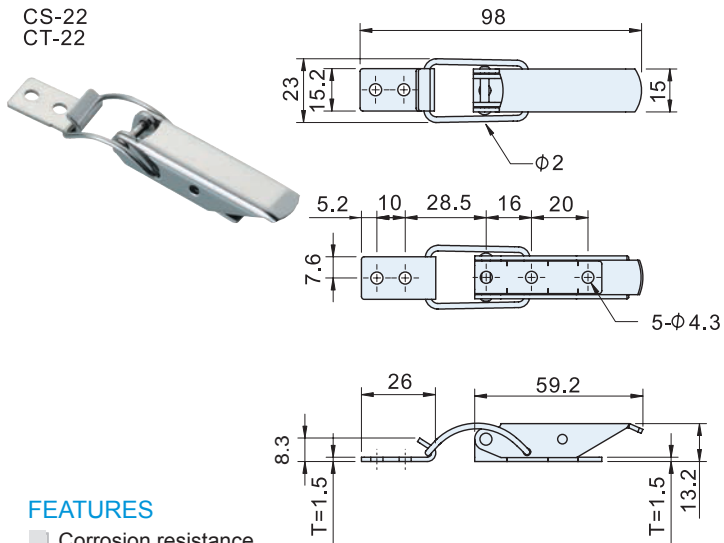

FEATURES

- Corrosion resistance.
- Provide compression force.
- The option are vertical keeper and horizontal keeper to been selected.

SPECIFICATIONS:

Unit:mm

Item No .	Material	Finish	Load capacity (kg)	Weight(g)
CS-22	SUS304	Vibration ground	30	38
CT-22	SPCC	Zinc plated		30